

Components

FLUIDCON

Pneumatic conveying has always been an acceptable means for transporting fine materials from one location to the other. From a positive point of view, the initial investment and maintenance costs are typically lower when compared to mechanical conveying systems.

However, the energy consumption for the air supply on conventional pneumatic systems is considerably higher than other options power requirements.

The Claudius Peters FLUIDCON system utilizes the advantages of typical pneumatic conveying at considerably lower energy requirements.

FLUIDCON has the benefits of less power consumption due to the incorporation of the aeroslide transportation principle within the transport pipe.

Additionally, it provides a dense phase system with increased bulk material load. Depending on the transport pipe routing, the new Claudius Peters FLUIDCON system can substantially reduce power consumption. FLUIDCON system can be used to convey all fine bulk solids which can be fluidized with low air velocities, and expands homogeneously during the process.

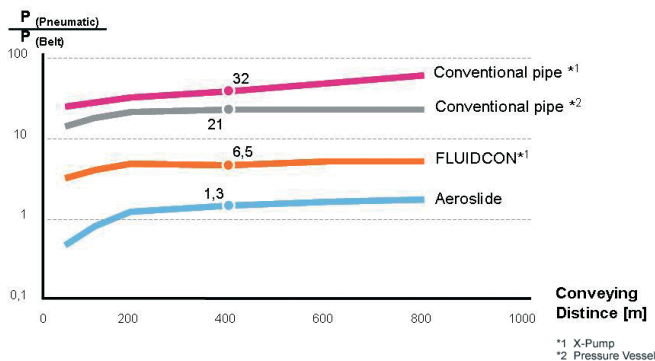
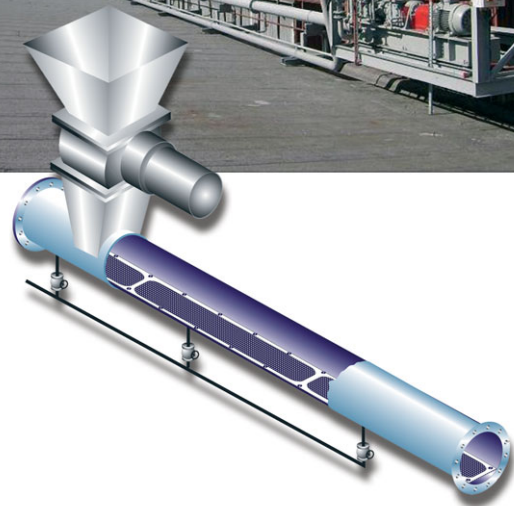

Advantages of Claudius Peters FLUIDCON Systems

- Reduced operating costs - substantially less energy consumption compared to conventional pneumatic conveying
- High availability - the system is easily started or restarted even when solids remain in the conveying line
- Gentle material handling - this is due to lower conveying velocities starting at approximately 2-3 m/s and ending at approximately 5 -10 m/s
- Alternative feed systems - with a reduction in the conveying pressure, Claudius Peters X-Pumps (screw pumps) can be installed instead of conventional pressure vessels to insure savings in height and capital costs

FLUIDCON

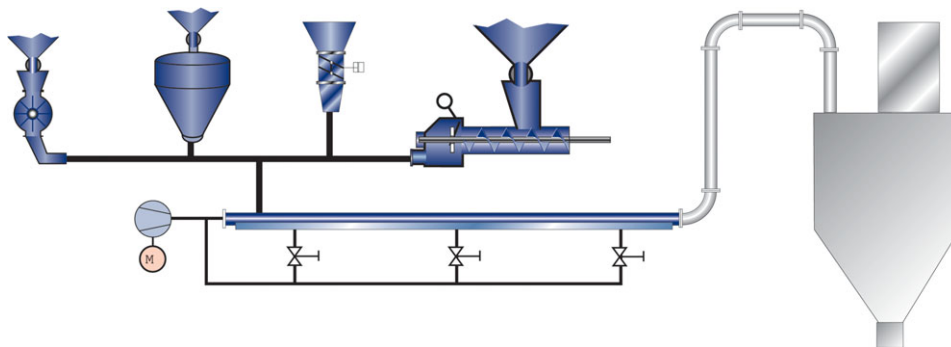

FLUIDCON is a conveyor pipe that can be partially or completely fluidized over the horizontal length of the pipe (the aeroslide principle). This air is used to fluidize but not to transport the material. The material transport air travels perpendicular to the fluidization air (the conveyor pipe principle) and passes in an axial direction. The pressure loss of the transport air flow substitutes for the inclination of an aeroslide. The Aeroslide principle turns the bulk solids into a fluid state with minimal internal friction and insures that the solids remain fluidized away from the bottom of the pipe and into the gas flow. These optimum conveying conditions allow the transportation of solids with lowest axial driving gas velocities in the feed point and acceleration section of the pipe. Therefore, it is possible to convey materials with minimal differential pressure and inclined uphill up to 30° with the FLUIDCON system.

The PETERS FLUIDCON system has proven to be a valuable alternative in bulk materials handling applications. Additionally this type of system can be utilized in ash removal plants. This system is particularly suitable for the removal of fly ash from a baghouse or ESP. The fly ash discharge points are connected to a common FLUIDCON conveying pipe and the ash is continuously removed and can be conveyed long distances.

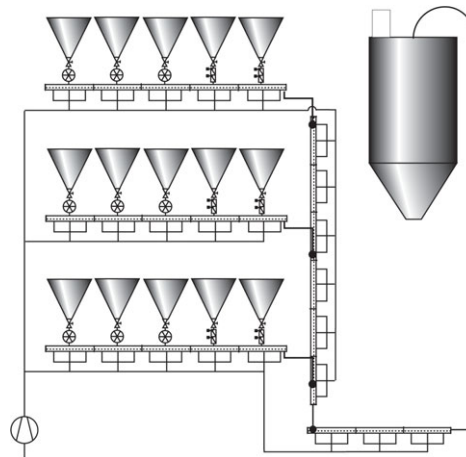

The application of the FLUIDCON system for the conveying of dust below filter installations offers the following advantages compared to other conveying installations.

- Lower investment cost
- Lowest gas and solids velocities
- Lowest conveying pressure
- Lowest wear
- Lowest power requirements
- Lower installation height
- Simplified material feeding



A Langley Holdings Company

Claudius Peters Projects GmbH

Schanzenstraße 40 | D-21614 Buxtehude | Germany

T: +49 4161 706-0 | E: projects@claudiuspeters.com

www.claudiuspeters.com

CP Components (GB) 09/2015/Issue 1

Due to the policy of continued improvement, we reserve the right to change any specification without prior notice.

ERRORS & OMISSIONS EXCEPTED