

X-Pump

The Claudius Peters X-Pump is a high-speed screw feeder which is installed as feeding unit in front of a pneumatic conveying pipeline. This pneumatic conveying system can be designed as conventional pneumatic pipeline system or as Claudius Peters FLUIDCON pipeline system.

The task of the X-Pump is to feed a defined solids mass flow into the conveying gas flow against the overpressure in the conveyor pipe, while at the same time sealing the system overpressure against the surrounding or the upstream sections of the plant to keep the gas leakage through the feeder as low as possible.

This sealing is realized by forming a plug of bulk solids of defined length at the end of the screw.

Conveying pressures up to approx. 2.5 bar overpressure, in special cases even higher, as well as conveying distances of up to approx. 1000 m and throughput capacities of up to approx. 400 t/h are achieved. It is possible to convey pulverized bulk solids as well as coarser materials with grain sizes up to approx. 10 mm. The X-Pump can be used as a feeder for dense-phase as well as for lean-phase conveyance.



Variable design and power transmission



Feeding of X-Pump by Claudius Peters discharge equipment

Advantages of Claudius Peters X-Pump

- Non-contact between screw / housing leads to less wear and high operation reliability
- Only end wing has to be exchanged not complete screw
- Flexible partial load operation due to sided bearing system
- No balancing of screw needed
- High sealing effect due to small gap between screw and wear bushing
- Non-contact labyrinth sealing ideal for higher screw speed
- Low maintenance costs and time
- X-pump designed for non explosive or explosive bulk materials like coal dust
- 100% ATEX conformity for feeding / transport of explosive bulk materials

X-Pump

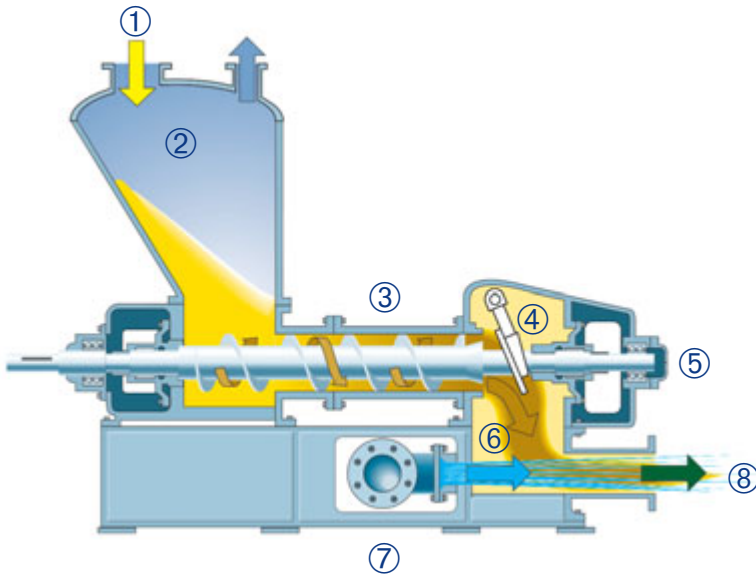

Main Components of X-Pump

1. Material inlet
2. Surge bin with dedusting socket
3. Conveying and compressing screw
4. Material discharge area
5. Double sided sealing and bearing system
6. Material / Gas mixing chamber
7. Conveying gas inlet
8. Conveying pipe connection

Summary

The Claudius Peters solid X-Pump is a very compact unit due to the two-sided bearing. The machinery runs extremely quiet and is characterized by very low power consumption and reduced pulsation during operation. The wear parts can be easily replaced, and the pump is suitable for a very wide range of applications and materials.

To sum it up it can be said that the Claudius Peters X-Pump is an excellent bulk feeding system for safety operation processes with highest plant reliability.

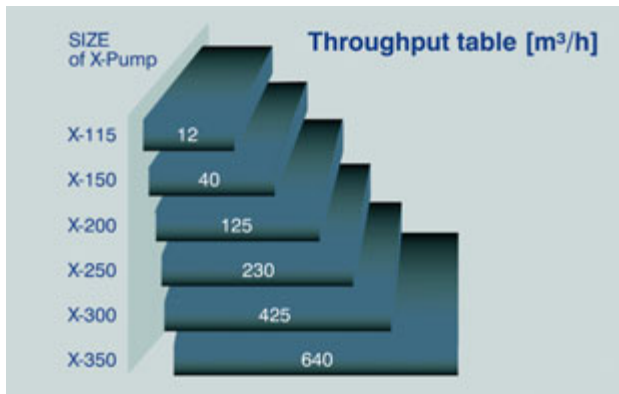

Highest flexibility in design of outlet points (example: left hand outlet)

Claudius Peters Projects GmbH

Schanzenstraße 40 | D-21614 Buxtehude | Germany
Tel: +49 4161 706-0 | Fax: +49 4161 706-270
projects@claudiuspeters.com

The information contained within this brochure is deemed to be correct at the time of going to press. Due to the policy of continued improvement, we reserve the right to change any specification without prior notice.
ERRORS & OMISSIONS EXCEPTED

CP Data X-P GB November 2011/Issue 1/JWN



CLAUDIUS PETERS

www.claudiuspeters.com

A Langley Holdings Company